

SIEMENS

Motor Control Centres 8PX3

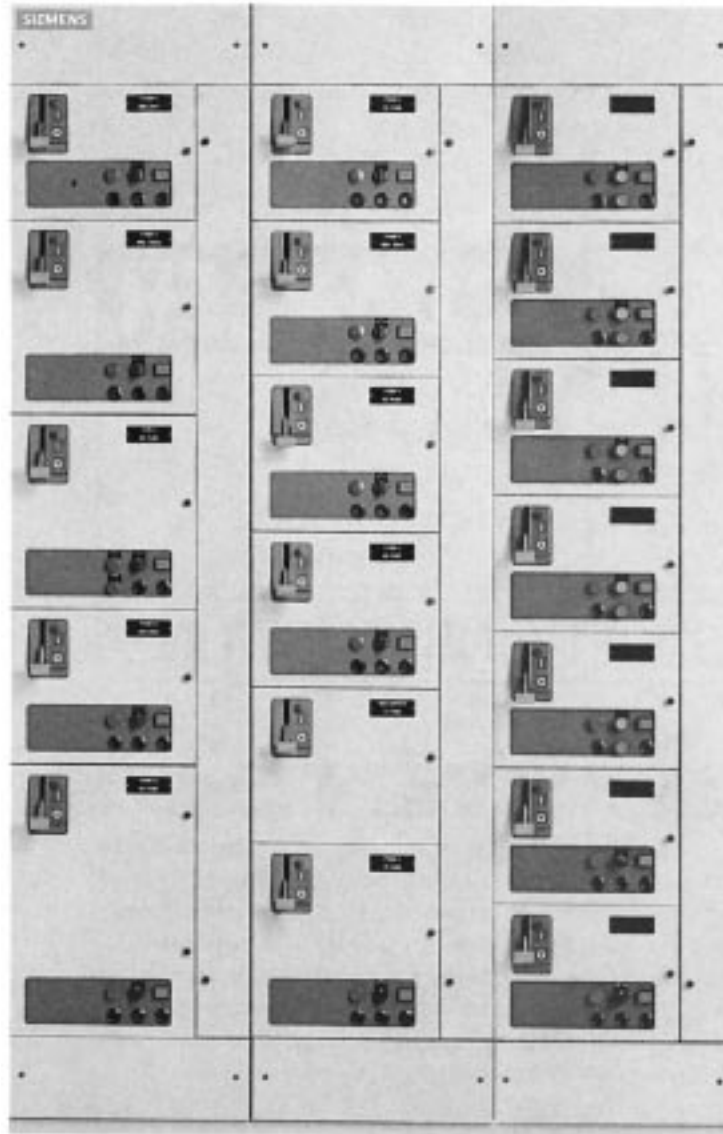

Installation and Maintenance Instructions

Note

Authorized and qualified personnel

For the purpose of this manual, a qualified person is one who is familiar with the installation, construction or operation of the equipment and the hazards involved. In addition, the person has the following qualifications:

- a) is trained and authorized to de-energize, clear, ground and tag circuits and equipment in accordance with established safety practices.
- b) is trained in the proper care and use of protective equipment such as rubber gloves, hard hat and safety glasses.
- c) is trained in rendering first aid.



! DANGER

**Hazardous Voltage.
Will cause severe
injury or death.**

**Turn power off supplying
device before installing.**

! SAFETY INSTRUCTIONS

Warning

Serious injury and equipment damage can occur through accidental contact with live wiring or bus system. Before beginning work on this or any other electrical equipment, disconnect and lock out incoming power and control voltage sources. Check all terminals with a voltmeter to ensure that the equipment is totally de-energized. Before power is restored, follow the procedures outlined in the pre-operation inspection section of this manual.

Table of Contents:

Nomenclature	ii
1.0 General Information	
1.1 Introduction	1
1.2 General Description	1
1.3 Operating Environment	2
2.0 Receiving and Handling	
2.1 Receiving	3
2.2 Handling	3
2.3 Storage	4
3.0 Installation	
3.1 Site Preparation	5
3.2 Mounting	5
3.3 Top and Bottom Covers	6
3.4 Joining Shipping Sections	6
3.5 Incoming Power Connections	7
3.6 Top Conduit to Upper Incoming Cable Compartment	8
3.7 Top Conduit to Main Breaker	9
3.8 Bottom Conduit to Main Breaker	9
3.9 Bottom Conduit to Vertical Bus Bars	10
4.0 Wiring Instructions	
4.1 Load and Control Wiring	11
4.2 Final Inspection/Checklist	12
4.3 Final Testing	13
5.0 Maintenance	
5.1 Routine Maintenance	14
5.2 Field Additions	16
5.3 Drawout Unit Removal and Replacement	16
5.4 Drawout Unit Addition	17
5.5 Torque Values	18
5.6 Installation and Adjustment of Motor Circuit Interrupter Protector	19
6.0 3RU Overload Relays	
6.1 Description	22
6.2 Single-Phase Protection	22
6.3 Manual or Automatic Reset	22
6.4 Overload Relay Selection Charts	24
6.5 Contactor Maintenance for SIRIUS Contactors 3RT1036 and larger.....	27
6.6 Contactors	29
7.0 Trouble shooting	30
8.0 MCC Optional Equipment	32

Nomenclature

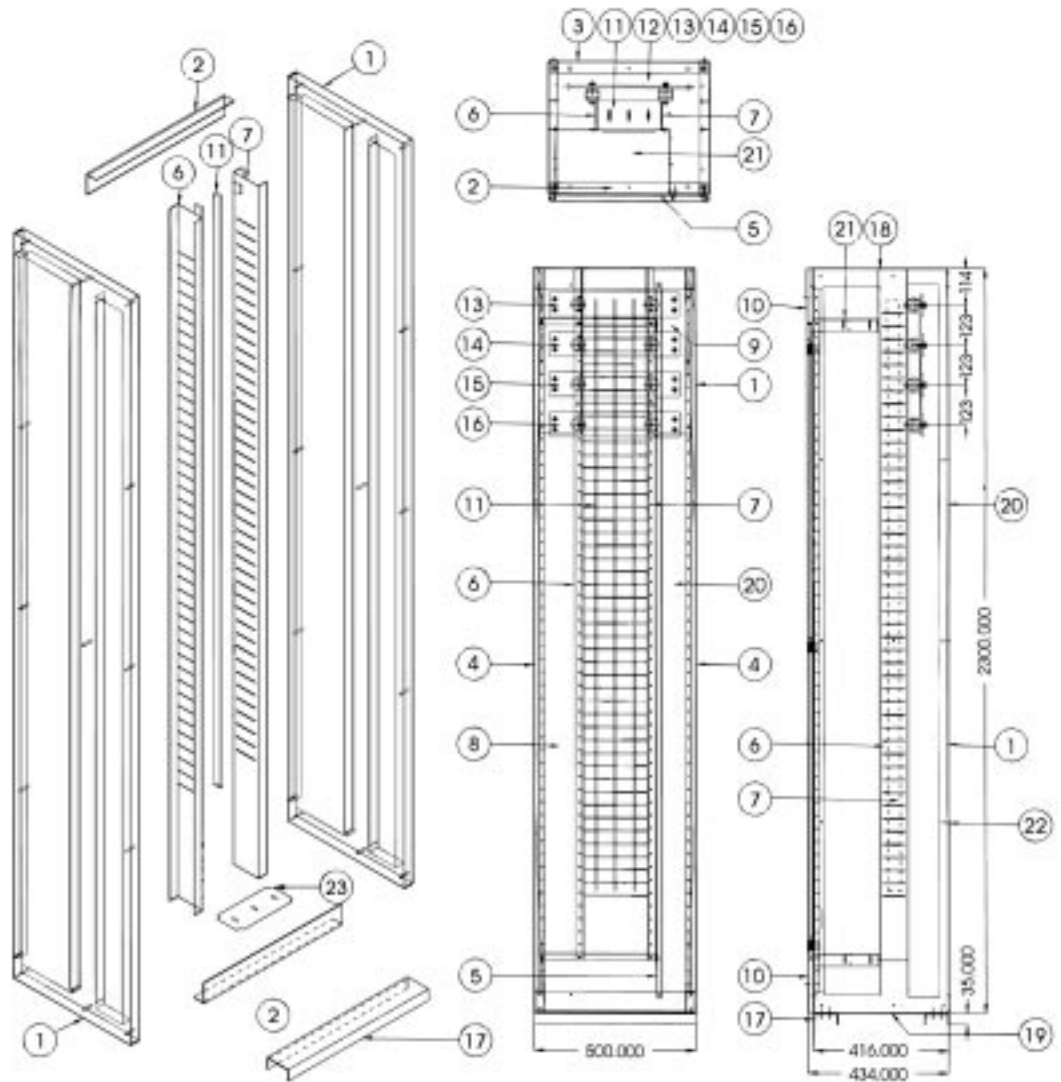

ITEM	DESCRIPTION	ITEM	DESCRIPTION
1	MCC FRAME F.O.B.	13	MAIN BUS LI
2	MCC BRACE	14	MAIN BUS L2
3	BACK PLATE 500 MM	15	MAIN BUS L3
4	END PLATE	16	NEUTRAL MAIN BUS
5	WIRE WAY U-POST	17	CHANNEL SILL 500 MM
6	B.B.CHANNEL LEFT SIDE	18	TOP COVER PLATE
7	B.B.CHANNEL RIGHT SIDE	19	BOTTOM COVER PLATE
8	LOWER B.B. CHANNEL	20	WIRING CHANNEL DOOR 24.5 M
9	UPPER B.B. CHANNEL	21	BUFFER PLATE
10	UPPER & LOWER FACE COVER	22	MAIN BUS COVER
11	VERTICAL BUS BAR	23	VERTICAL BUS SUPPORT
12	STAND-OFF INSULATOR		

1.0 General Information

Introduction - General Description - Operating Environment

1.1 Introduction

This instruction manual describes in detail the Siemens 8PX3 Motor Control Center. It has been prepared for the purpose of instructing personnel in the proper handling, installation, operation and maintenance of the control center. The 8PX3 MCC has been engineered to comply with CSA and EEMAC standards to meet today's industry requirements. These publications and this instruction manual should be thoroughly read and understood prior to beginning any work on the equipment.

1.2 General Description

The Siemens 8PX3 Motor Control Center is an integrated system of protective devices, electrical bus bars and control units gathered into compartments within a common enclosure consisting of one or more free-standing, deadfront structural frames. Each standard section is 500 mm wide, but may be up to 1000 mm wide depending on the size of the enclosed equipment.

Electrical power is distributed through the main horizontal bus mounted at the top and extending the length of the motor control centre. Each vertical frame containing provisions for drawout units is fed by a vertical bus system connected to the horizontal bus. The horizontal bus system is isolated from the front by a full-length steel barrier; an optional barrier may be installed to isolate the vertical bus.

Each vertical frame will accommodate up to seven 280 mm high control units in the front and, if so equipped, six in the rear if no neutral bus is provided. The control unit height may vary from a minimum of 280 mm up to 1960 mm. Most control unit assemblies through EEMAC Size 4 are drawout type.

Each control unit contains an operating handle extending through the door to switch the disconnecting means on and off.

The disconnecting means switched by the operating handle may be either a fusible disconnect switch or a circuit breaker which is coordinated with a contactor and an overload relay to form a basic control unit. Other auxiliary devices such as relays, transformers, switches and lights may be added to the basic unit.

1.3 Operating Environment

The 8PX3 Motor Control Center is designed for indoor applications to function efficiently under normal operating conditions at 5 to 40° C in a dry environment.

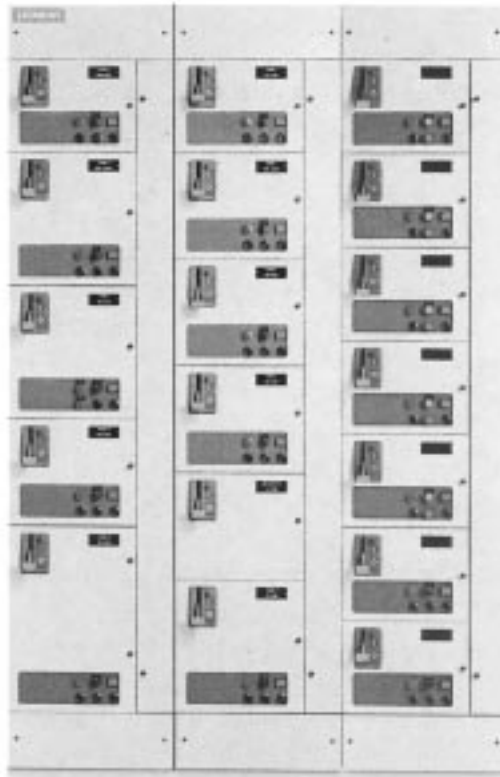

Three-Frame Motor Control Center,
front view

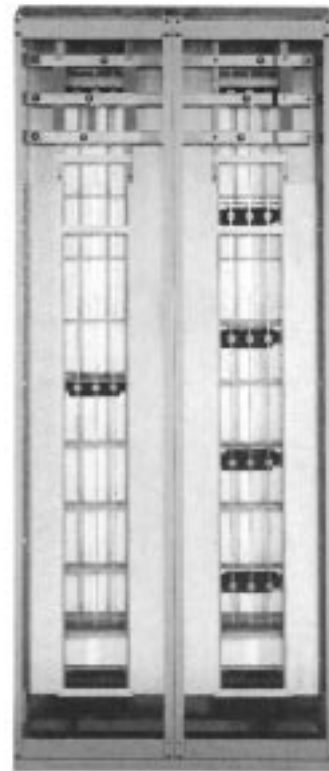

Two-Frame Motor Control Center,
rear view, back plate removed

2.0 Receiving and Handling

Receiving - Handling - Storage

2.1 Receiving

The 8PX3 Motor Control Centers are normally shipped from the factory completely assembled, inspected, tested and packed. If any damage which may have occurred during shipment is found, the receiver should immediately call it to the attention of the local freight agent handling the shipment. Siemens sales office should be notified.

2.2 Handling

8PX3 Motor Control Centers are shipped in groups of one to five vertical frames which are mounted on 100 mm x 100 mm wooden shipping blocks. When single frames are shipped individually, each is additionally mounted on a special pallet for further stability. Each shipping block is provided with two lifting angles on top for convenient handling.

The following table gives the approximate weights of single vertical frames and will be helpful in determining the required capacity of the handling means. If a vertical frame contains power factor correction capacitors, reactors or a large transformer, sufficient additional weight-handling capacity must be allowed.

Weight Table	
Frame Size	Weight
500 mm W x 434 mm D Front Only	280 KG
500 mm W x 550 mm Back-to-back	386 KG

Warning

Serious injury and equipment damage can occur if the 8PX3 Motor Control Center is moved with a wire rope "come along," pried or otherwise handled except by attachment to the noted lifting brackets. Always handle the control center in the vertical position. Restraints may be necessary to prevent tipping during handling, since the equipment weight is mostly at the top and front of the unit. Jacks, prybars, dollies, roller lifts and similar devices for lifting, handling, moving and lowering all require supplemental blocking beneath the MCC and restraints to prevent tipping. These devices are not recommended due to the hazards implicit in their use.

Due to the high center of gravity, precautions should be taken when moving an MCC with a forklift, or pipe rollers, to prevent shifting or tipping.

It is recommended that a crane or hoist be used to handle the MCC.

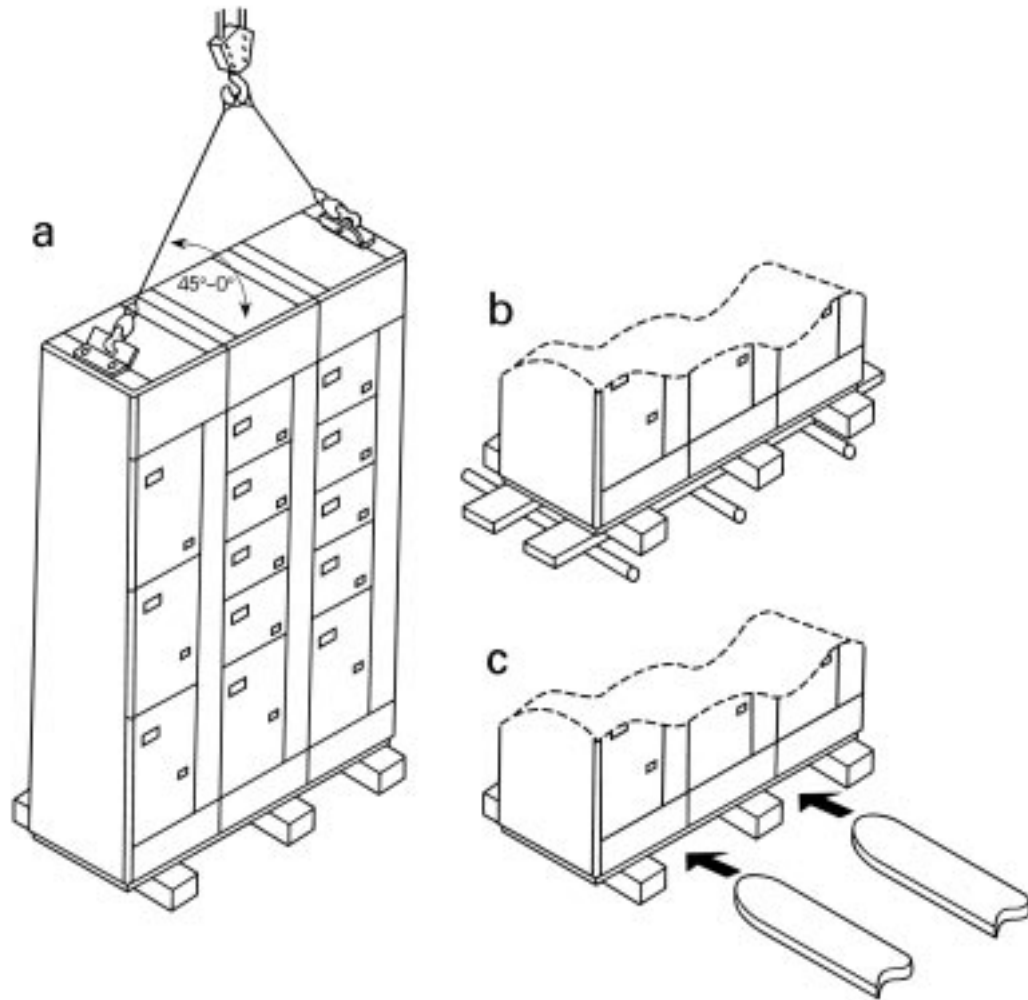

Handling of Motor Control Centre by

- a. Crane or Hoist
- b. Rollers
- c. Forklift

2.3 Storage

If storage is necessary, the equipment should be placed indoors in a clean, dry and protected location.

Periodic inspection of the storage is required to ensure proper condition of the equipment.

3.0 Installation

Site Preparation - Mounting - of Top and Bottom Covers - Joining Shipping Sections - Incoming Power Connections - Top Conduit to Upper Incoming Cable Compartment - Top Conduit to Main Breaker - Bottom Conduit to Main Breaker - Bottom Conduit to Vertical Bus Bars

3.1 Site Preparation

8PX3 Motor Control Centers are assembled in a special fixture to assure square construction and correct alignment of parts. A flat, level concrete surface should be prepared for the mounting site.

An uneven foundation may cause misalignment of shipping block units and doors.

3.2 Mounting

The coordination between the bolts and the MCC should be verified prior to attempting installation. Expandable inserts in predrilled holes or imbedded "L" bolts are recommended.

See the following figure for anchor bolt location.

The bolt size should be from 10 mm (3/8") to 12 mm (1/2").

Welding the steel base or sill channels to a steel floor plate is an alternate mounting method, especially recommended in areas subject to seismic activity.

The motor control center should never be placed on a floor made of flammable material such as wood (as per CSA C22.2 No. 14).

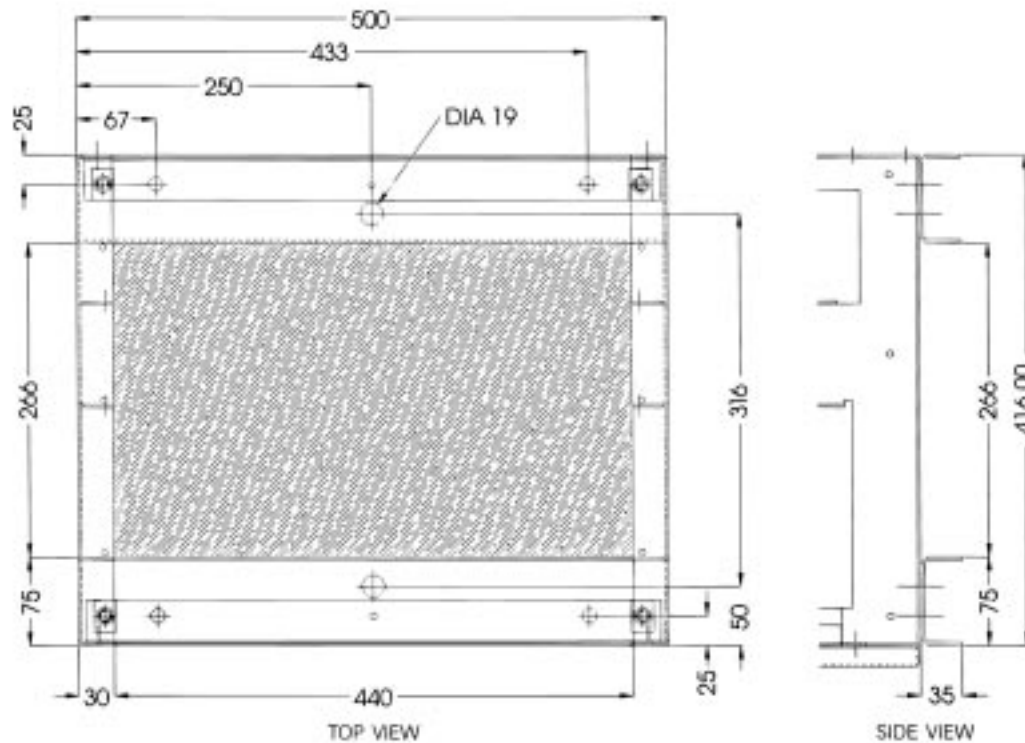

MCC Anchor Bolt Location

3.3 Top and Bottom Covers

Top covers are provided on all motor control centers as an integral part of the enclosure. Bottom covers are supplied on certain types of construction such as EEMAC 12. These covers should be removed only for the purpose of piercing holes for conduit or wire entry and must be immediately replaced to reduce the possibility that falling material, tools or personnel could unintentionally contact the bus system or other live parts.

3.4 Joining Shipping Sections

If it is necessary to join two or more shipping sections at the job site, the following procedures are recommended:

1. Position the first shipping section in place on the foundation and level.
2. Remove the front horizontal bus barrier. If rear is accessible, the back cover plates should be removed from the two mating frames.
3. Position the second shipping section on the foundation and level it. The horizontal bus should be inspected for proper positioning and alignment at this time.
4. Remove side bracing.
5. Position the right-hand MCC. Join the structures to each other by passing the joining bolts from the inside of the left-hand MCC wire way through the joining holes, into the right-hand MCC.
6. Join the ground bus between the two adjacent sections.
7. Assemble the bus bar links to join the horizontal power bus and neutral bus, if supplied, in the two shipping sections, as shown in the following figure. The horizontal and neutral buses may differ in size, material or plating; therefore, the links must be matched to the proper bars. All links and associated mounting hardware are provided with the MCC.
8. Tighten all bus connections to torques specified in Section 5.5, in the Maintenance section of this manual.
9. If the motor control center is wired per EEMAC Class II, connect the interunit wiring terminal blocks between shipping sections.
10. If there are other shipping sections to be joined, repeat steps 1 through 8 above.
11. Secure the motor control center to the foundation.
12. EEMAC 12 enclosure sections should be securely joined and sealed to prohibit intrusion of dust and moisture.
13. If MCC sections are supplied with insulated bus bars, carefully and securely tape the joints with electrical insulation tape.



Bus Connections between Shipping Sections

3.5 Incoming Power Connections

After all shipping sections are in place, levelled and joined together into a single motor control center, cables may be pulled and top entry conduit may be installed. Bottom entry conduit will have been stubbed through the floor at the proper locations prior to placement of the MCC. The incoming source cables may be connected at this time; however, the power source disconnecting means must remain open and locked out until all wiring is completed and the entire system has been checked out. Tighten all screw lugs and bolted electrical connections to the specified torque listed on page 18.

If crimp lugs are supplied, use only the crimping tool recommended by the lug manufacturer.

Caution

Remove top cover before drilling and cutting holes for conduit to prevent metal chips from falling into the motor control center.

To minimize the length of unsupported cable, the shortest, most direct routing should be chosen. All cables entering the control center must be adequately supported and restrained to withstand the maximum fault current capable of being delivered by the source. The recommended distances between straps for 36 kg rated straps are 150 mm for 22 kA bracing, 100 mm for 42 kA bracing, 75 mm for 65 kA bracing and 50 mm for 100 kA. Using a strap rated less than 36 kg will require the spacing distances to be reduced.

Warning

Do not connect the motor control center to a source which is capable of delivering fault currents greater than the interrupting or withstand ratings of the MCC or its units. Connection to such a source can result in equipment damage, serious injury or loss of life.

3.6 Top Conduit to Upper Incoming Cable Compartment

The following figure illustrates two cables per phase connected directly to the incoming line lugs. No. 6 through 350 MCM cables, one or two per phase, may be terminated in this manner. If more than two cables per phase are necessary, additional incoming compartment space will be provided. A minimum of 400 mm is not usable for control units at the top in a vertical frame containing an upper cable compartment. The amount of non-usable space depends on the quantity and size of incoming cables.

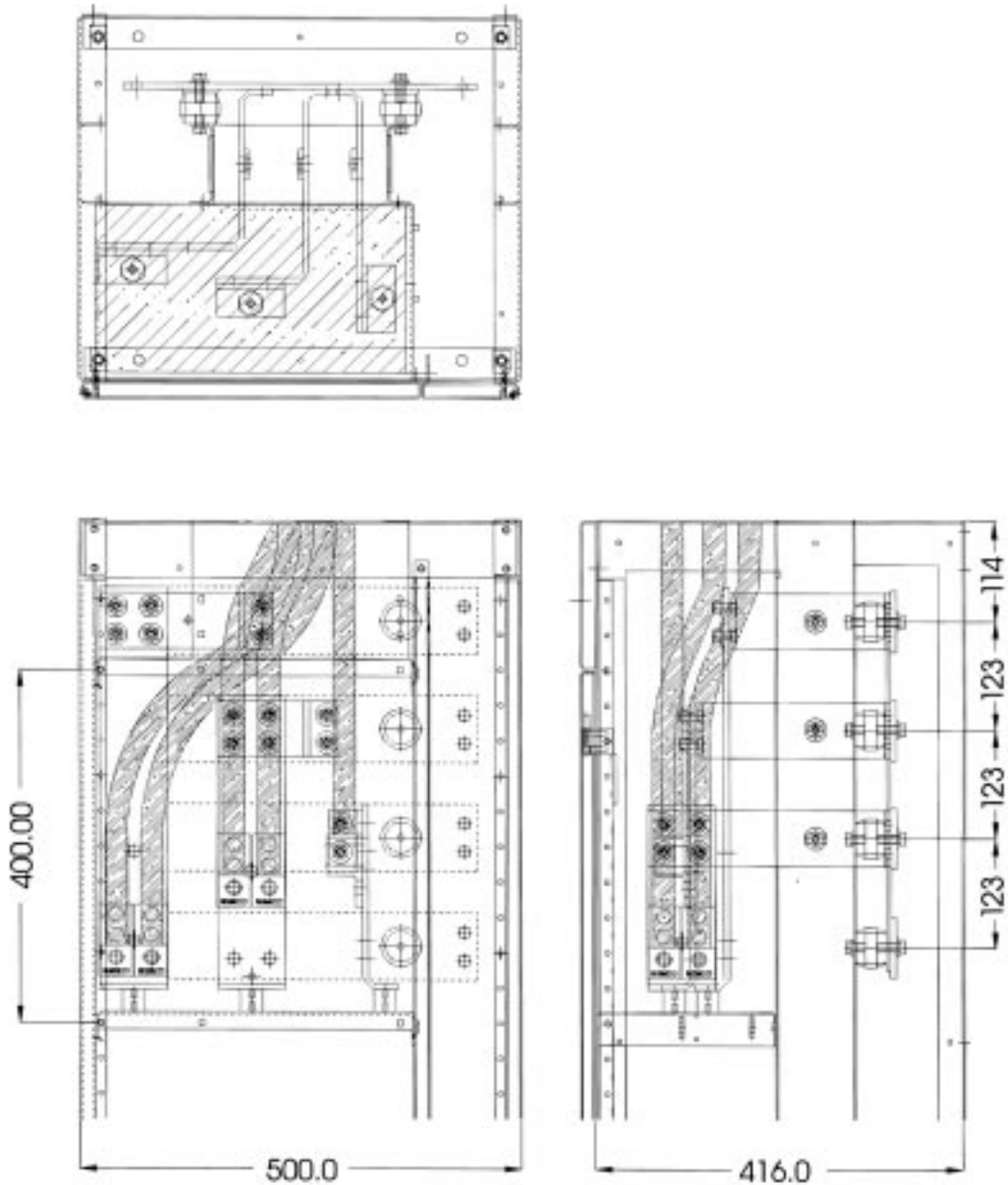

3.7 Top Conduit to Main Breaker

The following figure illustrates the connection of top incoming cables to a main incoming breaker. Refer to the lead sheet to determine the location of available control unit spaces within a frame containing a main breaker assembly. Greater cable support and restraint is required because of the longer cable.

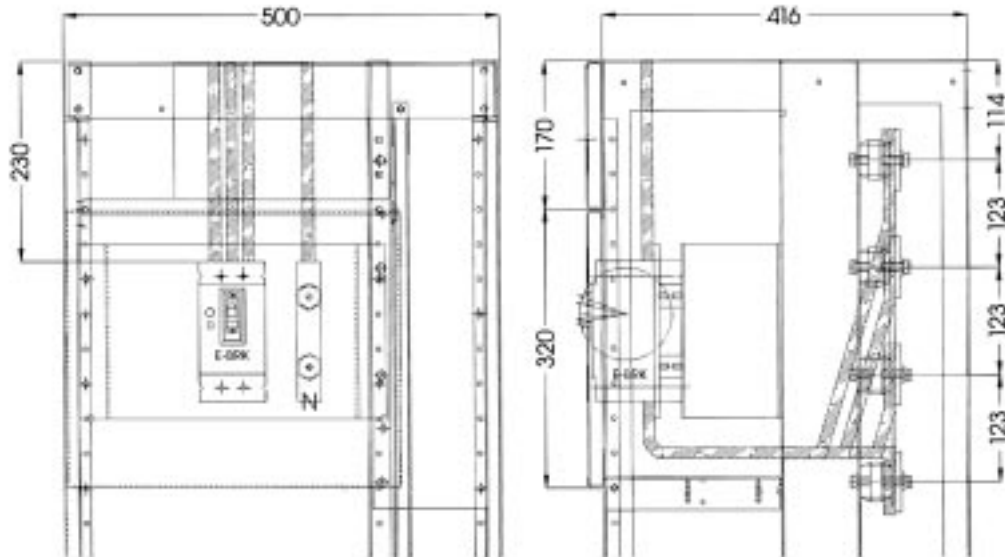

3.8 Bottom Conduit to Main Breaker

The following figure illustrates a main incoming breaker connected to cables from conduit stubbed up inside the frame bottom. The cables coming from the bottom should lie against the rear of the vertical wire space to allow room for the smaller unit cables and control wires. All cables should be laced securely to each other and to the cable supports provided to reduce distortion and damage in the event of a fault.

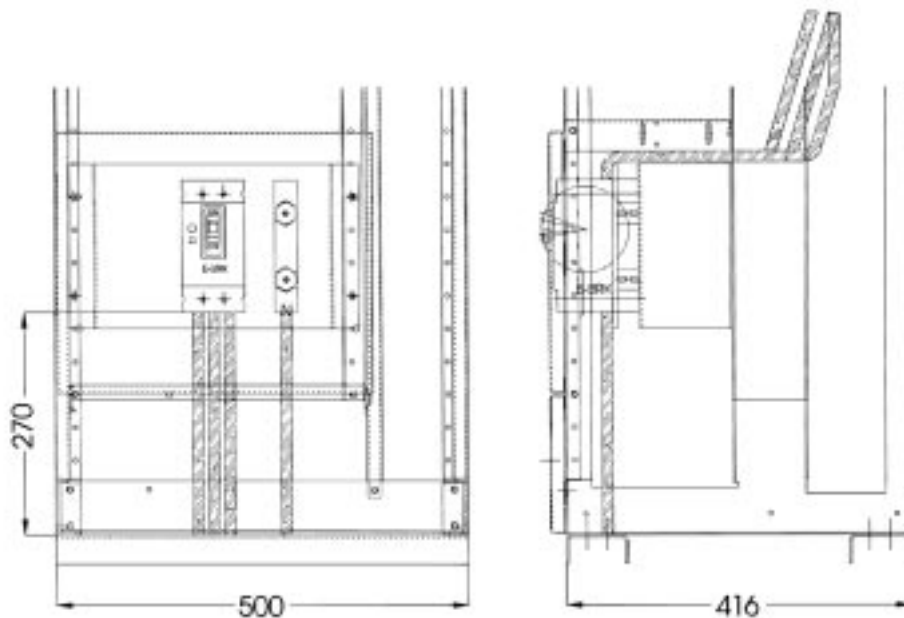

3.9 Bottom Conduit to Vertical Bus Bars

The following figure illustrates another bottom entrance option in which the incoming power cables terminate on a special vertical bus. Unless otherwise specified, pressure lugs are furnished for cable terminations. A minimum of 400 mm is not usable for control units at the bottom of a vertical frame containing this type of incoming cables.

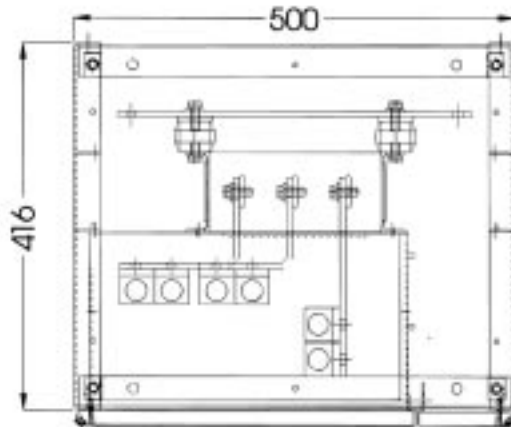

NOTE: 1-Y = 400 MM 2 X 500 MCM
2-Y = 480 MM 2 X 750 MCM

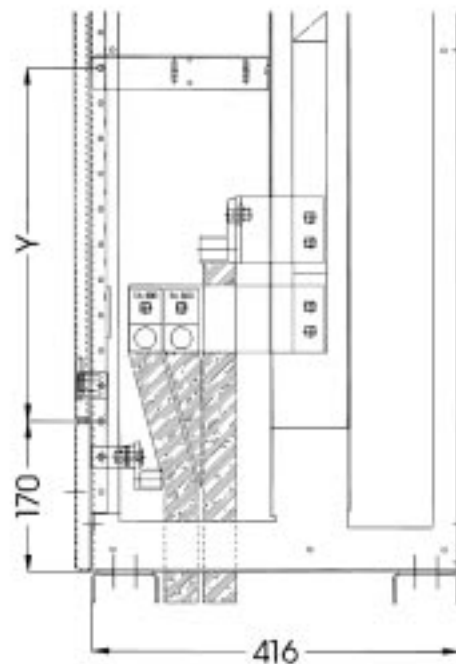
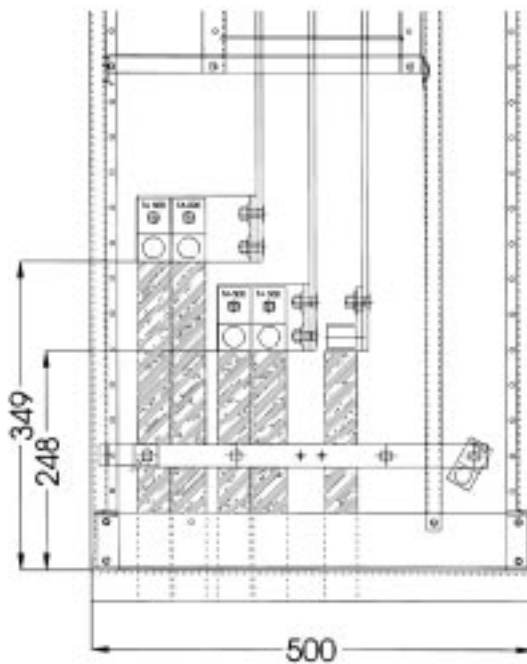

4.0 Wiring Instructions

Load and Control Wiring - Final Inspection / Checklist - Final Testing

4.1 Load and Control Wiring

All interconnections between devices within each control unit are prewired at the factory. Field wiring to each control unit should be made in accordance with the wiring diagram indicated on the lead sheet for that particular unit. When wiring or performing any maintenance on drawout units, disengage the stabs by withdrawing the unit. Never attempt to disengage the stabs with the circuit breaker or disconnect switch in the "ON" position. Wiring done with the pan in this position will ensure adequate cable slack to allow unit withdrawal to the same position when future maintenance is required. Always use stranded wire.

Warning

The vertical bus is completely exposed when the unit is withdrawn if no barrier is present.

The vertical wiring between control units or between a control unit and conduit should be pulled through the wiring space on the right side of the frame. These wires should then be tied or laced together and the resulting bundle then securely fastened to the wire supports.

4.2 Final Inspection/Checklist

Every motor control center that leaves the Siemens plant is thoroughly inspected and tested completely before shipment to customer. After the equipment has been installed in place and all wiring and cables have been connected, the final inspection and test should be done before the equipment is energized and put in service.

The following points are to be checked:

- All incoming primary cables and buses, including connection according to the wiring diagrams. Ensure that all electrical spacings and clearances phase-to-phase and ground-to-phase are maintained in accordance with CSA Standard requirements.
- Equipment must be clean and free from dust and dirt which has accumulated on the control centers during installation.
- All cables and bus connections should be tight and properly torqued in accordance with the torque values specified on page 18.
- Remove temporary wiring jumpers used on the secondaries of the current transformer tied to the external devices. Refer to wiring diagrams for all connections shown.
- Check that proper fuses are installed.
- Check for proper ground connection.
- Check that all bus bars and connections (if applicable) are properly insulated.
- Check that all blocking supports and other temporary ties are removed from the contactors, relays and other devices.
- Check that all equipment that was removed from the MCC during installation is replaced and installed.
- Check that interlocks are functioning properly.
- Check that all structural panels and covers are installed.
- Check that all nameplates and operating instruction labels, including the safety labels, are installed.

4.3 Final Testing

The megger test is used to conduct an electrical insulation resistance test to make sure that equipment is free from short circuit between phases to ground and that no leakage paths exist at the insulators due to surface dirt or the presence of absorbed moisture.

The test is conducted by applying 1000 volts DC for 1 minute between phase-to-phase and phase-to-ground. In all cases, the measured resistance must equal or exceed $KV + 1$ Megohm. For acceptance where KV is the MCC rating in Kilovolt, i.e. MCC rating voltage is 600 V, megger test voltage = 1000 V DC, minimum insulation resistance for acceptance = 1.6 Megohm.

High Potential Test

If it is necessary that a high potential test be done on the equipment which, was previously tested at the factory, the high potential test will be applicable as follows:

Rated 250 volts : 75% of 1500 volts or 1125 volts

Rated 600 volts : 75% of 2200 volts or 1650 volts

Rated 480 volts : 75% of 1960 volts or 1470 volts

Secondaries and control : 75% of 1500 volts or 1125 volts

Caution

Certain control devices may not be subjected to the test voltage of 75% of 1500 V or 1125 V but 75% of 900 volts or 675 volts. Rated voltages of these devices must be verified before testing. The test voltages above are for use at altitudes not over 3300 feet above sea level in an ambient temperature not exceeding 40 °C.

5.0 Maintenance

Routine Maintenance - Field Additions - Drawout Unit Removal and Replacement - Drawout Unit Addition Torque Values - Installation and Adjustment of MCP

Severe environmental conditions or equipment usage will require more frequent inspections and maintenance. The items in Section 5.1 should be included on any comprehensive maintenance checklist.

Warning

**All compartments may contain hazardous voltages.
Use safety precautions when energizing or servicing
this equipment.**

5.1 Routine Maintenance

It is recommended that the following maintenance be performed on a regular basis with the motor control de-energized and incoming power locked out:

1. Feel the doors, enclosure sides and deadfront surfaces over all circuit breakers and switches with the palm of the hand. Any surface with a temperature which the palm of the hand cannot stand for about 3 seconds may indicate trouble. Heat detectors are also available to detect trouble spots.
2. Wipe all bus insulators and vertical bus barriers and vacuum any accumulation of dust.
3. Check the following for tightness:
 - a. Bus connections (Torque main bus bolts to prescribed limit on page 18).
 - b. Power cable connections.
 - c. Control wire connections.
4. Inspect all wiring for insulation deterioration, wear or cuts. Replace if necessary.
5. Look for wear of the plating on the unit stab fingers and on the vertical bus at the location where the unit stab fingers engage the vertical bus. The plating is part of the environmental protection system for the copper. Oxide and/or other films can form on exposed copper or aluminum, resulting in a poor contact.

These parts must be replaced when the plating is worn to the point where copper can be seen, because contact resistance becomes higher, increasing the heat generated at the contact point, which, in turn, may lead to arcing and possible bus flashover.
6. Check all operating handles and mechanical interlocks for proper operation.
7. Check and replace defective pilot lamps.
8. Inspect starter contacts and replace if over half-eroded. Do not dress silver alloy contacts. Replace contact springs at the same time the movable contacts are replaced.
9. Look for indications of overheating, arcing or insulation breakdown and replace defective parts.

10. Remove drawout assemblies and check stab and unit wiring. Vacuum any accumulated dirt.
11. Visually inspect all instruments and check instrument calibrations.
12. Always replace fuses with those of the same type and rating. Even though another replacement fuse may be physically interchangeable with the original, it may not have the same short circuit-interrupting capacity and current-limiting ability.
13. Lubricate the stab fingers with Siemens contact lubricant before replacing drawout assemblies.
14. Operate each switch or circuit breaker several times to ensure that all mechanisms are free and in proper working order.
15. Check all devices for missing or broken parts, proper spring tension, free movement, rusting or corrosion, dirt and excessive wear.
16. Look for any moisture or signs of previous wetness or dripping inside the MCC. Condensation in conduits or dripping from outside sources is a common cause of control center failure. If evidence of moisture is found, seal all cracks and openings and eliminate all sources of moisture such as those which cause a dripping on the MCC enclosure.
17. Refer to component instruction books for periodic maintenance of component assemblies.

Caution

Do not oil or lubricate the armature or magnet assembly in any contactor or relay. The lubricant attracts dust and impedes the proper operation of the armature.

5.2 Field Additions

Field additions may be made to the control center if the current rating of the main or vertical bus is not exceeded. The preparation of the floor and conduit is the same as in a new installation. Any new shipping section will contain all of the necessary hardware and bus connecting links. De-energize the existing motor control center and remove the end side plates from the existing vertical frame which is to be joined. After joining the structures in accordance with the instructions in the Installation section of this manual, the field inspection and testing must be performed.

Additions to motor control centers fall into two general categories: a) additions of frames and b) additions or replacement of drawout units. The addition of frames is similar to the installation of control centers which have been shipped in several sections. When mounting methods or models of new and existing sections differ, care must be exercised to ensure proper alignment of horizontal bus.

Field additions of drawout units may be as simple as installing the assembly into a spare space or as elaborate as replacing two small units with a larger one. In either event, the procedure is basically the same, and all necessary parts and hardware will be supplied. See the Drawout Unit Removal and Replacement section for details.

All wiring must be done in agreement with the unit wiring diagram supplied with the drawout unit and the wiring instructions detailed in the Installation section of this bulletin.

Warning

Insufficient bracing can result in serious injury and equipment damage. Verify that the available power source fault current has not been increased when adding frames or drawout units. The existing MCC and new additions may not be properly braced if the available fault current has been increased.

5.3 Drawout Unit Removal and Replacement

The following sequence should be followed when removing a drawout unit:

1. Turn unit off using the STOP button or selector switch.
2. Push the disconnecting means operating handle to the "OFF" position.
3. With a screwdriver, turn the quarter-turn door fastener 90° counterclockwise and open the door.
4. Turn the drawout unit latch by 90°.
5. Separate pull-apart terminals, if supplied, or disconnect wires from terminal blocks, tag and secure within the MCC.
6. The drawout unit may now be easily removed from the frame.
7. The drawout unit should be protected from abuse, dust and moisture while it is not mounted in the MCC.

5.4 Drawout Unit Addition

Drawout units may easily be added to the 8PX3 Motor Control Center to fill blank spaces. Each unit comes complete with horizontal mounting plate, door and hinges. The following is the installation procedure for these units.

1. Remove the cover(s) over the blank section(s) equal to the drawout unit height.
2. Horizontal mounting plates are installed by fastening the rear into place with three self-tapping screws and the front with two self-tapping screws in the predrilled vertical channels.
3. Use the new door as a template to locate the positions of the hinges. Self-tapping screws in predrilled holes are used to bolt the hinges to the left-hand corner channels.
4. Remove the vertical bus barrier insert.

Warning

Live bus is exposed through the access hole. Contact with the bus can result in serious injury, loss of life and equipment damage.

5. Push the disconnecting means operating handle to the "OFF" position.
6. Install the drawout unit onto the mounting plate and push in the unit **without** engaging the stabs.

Warning

**Do not allow the stab to engage the vertical bus at this time!
Stab engagement will energize terminals exposed to operating personnel and can result in serious injury.**

7. Connect all power cables and control wires in agreement with the unit wiring diagram and the instructions detailed in the Wiring Instructions section of this manual.
8. Review and perform the procedures for units as listed in the Final Inspection/Checklist on page 12.
9. Push the drawout unit in towards the bus until the stabs are firmly connected to the bus. If the unit is twisted during insertion, it will not fully engage onto the vertical bus.
10. Close the door and secure it with the quarter-turn fasteners. If the drawout unit is not properly inserted, the door will not close. **Never force the door to close!**
11. Move the handle to the "ON" position. The control unit is now ready for operation.
12. Repeat Steps 1 through 11 for each additional new drawout unit to be added.

5.5 Torque Values

Tolerance: +5% - 0%

Tolerance

Thread-Forming Screws				
Screw Size	Torque in Inch Pounds			
	Up to .187		Over .187	
	AL	CU	AL	CU
8 – 32	30	50	30	50
10 – 24	30	50	30	50
1/4 – 20	30	72	50	72
5/16 – 18	–	–	–	–

Grade 5 Bolts with Grade 2 Nuts	
Bolt Size	Torque in Foot Pounds
	All Thickness AL & CU
1/4 – 20	6
5/16 – 18	12
3/8 – 16	20
1/2 – 13	50

Belleville Washer Nuts	
Bolt Size	Torque in Foot Pounds
	All Thickness AL & CU
1/4 – 20	6
5/16 – 18	12
3/8 – 16	20
1/2 – 13	50

Conversion Tables



Read down

Units to Be Converted ▼	Imperial			Metric			International System – S.I.		
	Ozf-in	lbf-in	lbf-ft	gf-cm	kgf-cm	kgf-m	mN-m	cN-m	N-m
1 ozf-in =	1	0.0625	0.005	72	0.072	0.0007	7.062	0.706	0.007
1 lbf-in =	16	1	0.083	1152.1	1.152	0.0115	113	11.3	0.113
1 lbf-ft =	192	12	1	13.826	13.83	0.138	1356	135.6	1.356
1 gf-cm =	0.014	0.0009	0.000 07	1	0.001	0.000 01	0.098	0.01	0.0001
1 kgf-cm =	13.89	0.868	0.072	1000	1	0.01	98.07	9.807	0.098
1 kgf-m =	1389	86.8	7.233	100 000	100	1	9807	980.7	9.807
1 mN-m =	0.142	0.009	0.0007	10.2	0.01	0.0001	1	0.1	0.001
1 cN-m =	1.416	0.088	0.007	102	0.102	0.001	10	1	0.01
1 N-m =	141.6	8.851	0.738	10.197	10.20	0.102	1000	100	1

Example 1

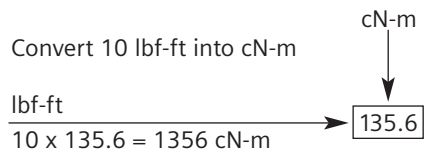

Example 2

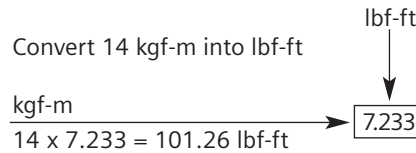

5.6 Installation and Adjustment of Motor Circuit Interrupter Protector

Siemens Instantaneous Trip Motor Circuit Interrupter Type ED63A and CED63A 600 VAC

For Use With: Combination Motor Controllers

	⚠ DANGER
	<p>Hazardous Voltage. Will cause severe injury or death.</p> <p>Turn power off supplying device before installing.</p>
⚠ SAFETY INSTRUCTIONS	

Note: This instruction outlines the recommended installation procedure.

Mounting Procedure for Motor Circuit Interrupter Protector:

1. Turn off power supplying this device before setting trip range or servicing.
2. Prior to mounting motor circuit interrupter, manually exercise handle from "OFF" position to "ON". Then push the trip button.

This operation procedure will ensure mechanical operation of the motor circuit interrupter.

3. Use four mounting screws for Type ED63A or six for Type CED63A and associated flats from kit catalogue number MSE6 to bolt the motor circuit interrupter onto the customer-supplied mounting plate assembly.

Adjustment Procedures for ETI Motor Circuit Interrupter Protector:

1. Motor circuit interrupter continuous current rating should not be less than 115% of Motor Full Load Current (MFLC). The MFLC is obtained from the motor nameplate.
2. The instantaneous setting is determined by multiplying the MFLC by 11. Select the closest setting, but it must be under 13 x MFLC. In order to comply with the Canadian Electrical code, Part 1,* adjust the instantaneous button by rotating to the current determined in the previous step.

Example:

$$\begin{aligned}
 20 \text{ HP } 460 \text{ V AC} &= 27 \text{ ampere MFLC} \times 115\% \\
 &= 31 \text{ amps continuous current rating} \\
 &= 40 \text{ ampere interrupter} \\
 27 \times 11 &= \text{position 4 setting}
 \end{aligned}$$

A convenient conversion table is supplied below. This chart does not cover all application or motor current values, but does cover most commonly used three-phase motors.

Conversion Tables

Motor HP Rating			Contin. Amps	Trip Range					Setting		
208V	460V	575V		LO	2	3	4	HI	208V	460V	575V
–	1/4	1/4	1	2.6	4.5	6	7.5	9	–	3	2
1/4	1/2	1/2	2	7	11	15	19	22	2	2	2
1/3	3/4	3/4	2						4	3	2
–	–	1	2						–	–	3
3/4	1.5	1.5	5	16	26	36	46	54	3	2	2
1	2	2	5						4	3	2
1-1/2	3	3	10	30	50	70	85	100	3	2	2
2	5	5	10						4	4	4
3	7-1/2	7-1/2	25	55	90	125	155	180	3	3	2
–	–	10	25						–	–	3
5	10	15	30	80	135	185	235	270	3	2	3
–	15	–	30						–	4	–
7-1/2	20	20	40	115	185	255	325	375	3	4	3
–	–	25	40								4

Note:

Conversion current rating -1.15 times MFLC.

Setting based on 11 times MFLC (or a setting just above peak in-rush current).

Motor circuit interrupter instantaneous value tolerance levels are determined by UL 489 Standards +/- 20% of marked settings.

Handle operating forces:

“ON” to “OFF” : 8-10 lbs.

“OFF” to “ON” : 8-10 lbs.

Relatch : 14 lbs.

*CSA allows 215% of the motor locked rotor current where indication is given.
C22-1-28-210

Screw Replacement

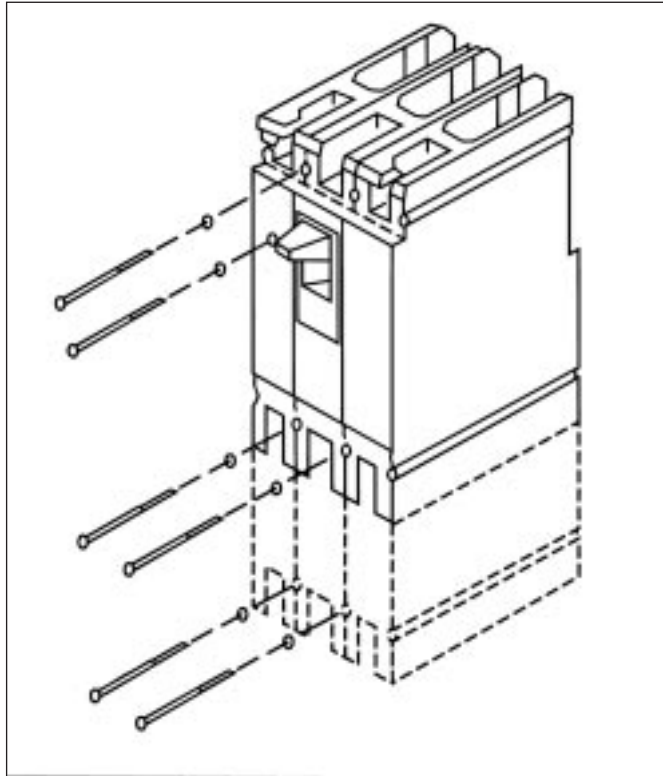

Trip Adjustment

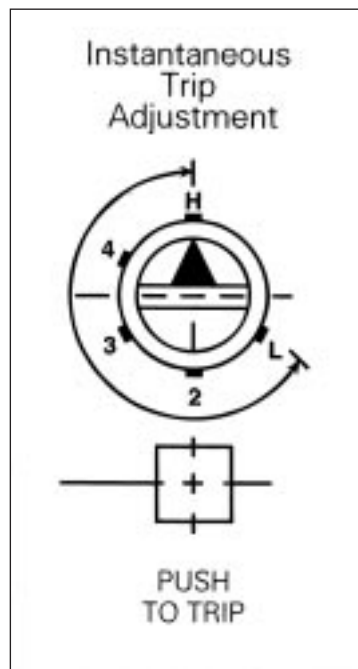

6.0 3RU Overload Relay

Description - Single Phase Protection - Manual or Automatic Reset - Overload Relay
Selection Chart - Contactor Maintenance - Contactor Selection Chart

6.1 Description

The 3RU three-phase thermal overload relay is an EEMAC Class 10, directly heated, front adjustable, ambient temperature-compensated bimetallic device. The relay is supplied with one normally closed contact for opening the control circuit in case of thermal trip and one normally open contact to provide a remote alarm indicator.

6.2 Single-Phase Protection

In addition to motor overload protection, the internal trip mechanism provides motor single-phase protection. See page 23: Curve 1 shows the normal three-phase time-current tripping relationship. The relay senses a loss of phase condition and shifts the time-current tripping response curve to the left, as shown by Curve 2. As a result of this curve shift and the higher single-phase current, the tripping time of the overload relay will be reduced.

6.3 Manual or Automatic Reset

The 3RU overload relay is set for HAND reset operation when shipped from the factory. The relay may be set for AUTO operation by depressing and turning the blue reset button counterclockwise to the position marked "A." See photo on page 23.

Warning

Automatic reset should not be used with two-wire control or where automatic resetting of the overload relay would restore power to the motor, endangering either personnel or equipment.

Calibrated for Service Factor of 1.15

A large percentage of today's motors are rated for a service factor of 1.15. To assure optimal protection, simply adjust the dial as shown below.

Motor service factor	Adjustment
1.0	Motor nameplate F.L.A. x 0.92
1.15	Motor nameplate RL.A

3RU OLR Time-Current Tripping Curves

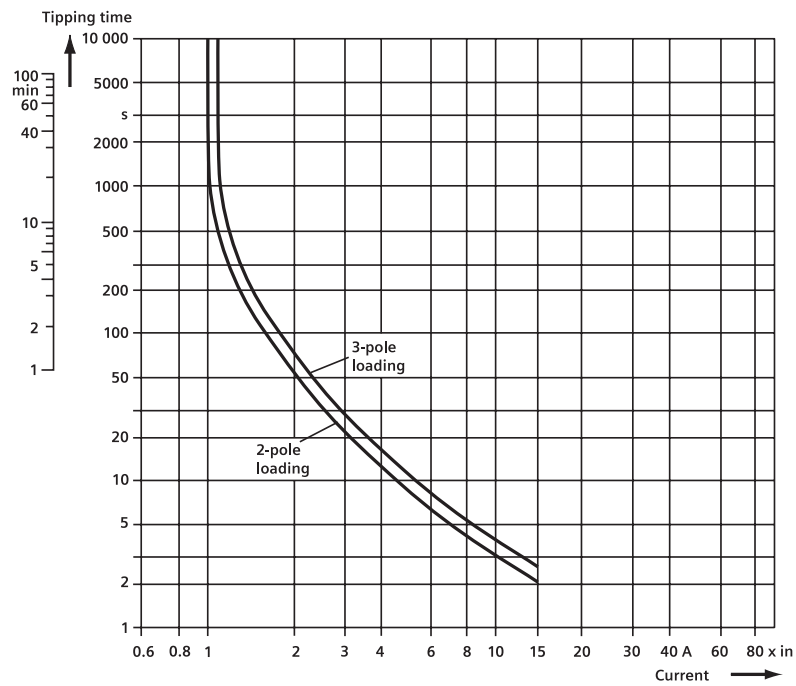

3RU Curves

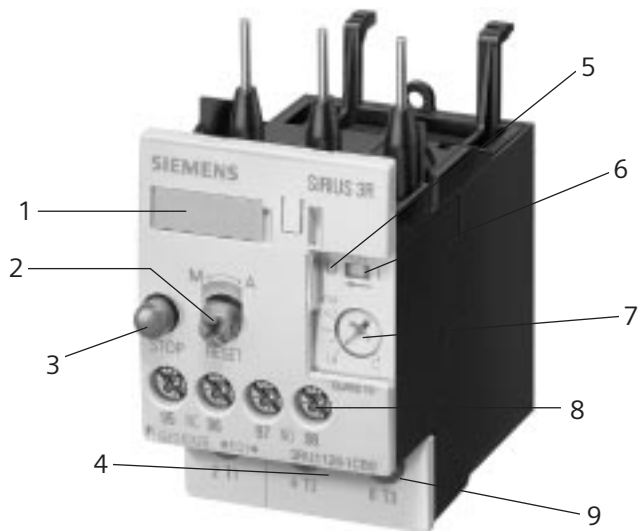

1. Equipment designation label
2. Manual/automatic RESET selector switch
3. STOP button
4. Complete order number on the front of the device
5. Transparent cover, sealable (secures adjuster knob for rated motor current. TEST function and Manual/Automatic RESET setting)
6. Switching position indication and TEST function
7. Adjuster knob for rated motor current
8. Repeat coil terminal (for mounting onto contactors)
9. Auxiliary switch repeat terminal (for mounting onto contactors)

Maximum Settings of Overload Relays

Motor Service Factor Characteristic	Maximum Setting Multiply Motor FLA by:
Motor service factor equal to or greater than 1.15	1.00
Motor Temperature rise less than or equal to 40°C	1.00
All other motors	0.92

6.4 Overload Relay Selection Chart

Type 3RU bimetallic type overload relays are supplied with built-in heater elements. They provide, as a standard:

- three-pole overload protection
- ambient temperature compensation
- phase-failure (single phasing) protection
- alarm contact 1 N.O.
- field adjustability
- overload test button
- The overload relay calibration is based on a motor service factor (S.F.) of 1.15. If the service factor is 1.0, multiply motor Full Load Current by x 0.92 before making selection.

Selection and Adjustment Procedure:

1. Establish the starter size or contactor type the overload relay is to be fitted to.
2. Determine motor full load current and service factor* from motor nameplate.
3. Place the motor full load current within the corresponding setting range listed below and simply select the overload relay type number shown opposite in the correct starter, size column.
4. Once the overload relay is installed, adjust the setting dial to:
 - motor full load current if S.F. 1.15.
 - motor full load current x 0.92 if S.F. 1.0 or is unmarked.

*See Overload Selection Table on pages 25 and 26.

Overload Relay

SIRIUS 3RU11 Bimetallic Class 10 Overload Relays with Screw Terminals

Description

Class 10, ambient compensated bimetallic Overload relays for direct mounting to 3RT10 Contactors. For separate mounting when Used in conjunction with 3RU19 separate Mount kits.

Features

1NO & NC auxiliary contacts
Manual/automatic RESET
Trip indicator
STOP button
Test function
Sealable cover
CSA, UL

For Contactor Type	Setting Range Amps	Catalogue No.
3RU111-for direct mounting to 3RT101 contactors		
3RT1015	0.11–0.16	3RU1116-0AB0
3RT1016	0.14–0.2	3RU1116-0BB0
3RT1017	0.18–0.25	3RU1116-0CB0
	0.22–0.32	3RU1116-0DB0
	0.28–0.4	3RU1116-0EB0
	0.35–0.5	3RU1116-0FB0
	0.45–0.63	3RU1116-0GB0
	0.55–0.8	3RU1116-0HB0
	0.7–1.0	3RU1116-0JB0
	0.9–1.25	3RU1116-0KB0
	1.1–1.6	3RU1116-1AB0
	1.4–2	3RU1116-1BB0
	1.8–2.5	3RU1116-1CB0
	2.2–3.2	3RU1116-1DB0
	2.8–4	3RU1116-1EB0
	3.5–5	3RU1116-1FB0
	4.5–6.3	3RU1116-1GB0
	5.5–8	3RU1116-1HB0
	7–10	3RU1116-1JB0
	9–12	3RU1116-1KB0
3RU112-for direct mounting to 3RT102 contactors		
3RT1023	1.8–2.5	3RU1126-1CB0
3RT1024	2.2–3.2	3RU1126-1DB0
3RT1025	2.8–4	3RU1126-1EB0
3RT1026	3.5–5	3RU1126-1FB0
	4.5–6.3	3RU1126-1GB0
	5.5–8	3RU1126-1HB0
	7–10	3RU1126-1JB0
	9–12.5	3RU1126-1KB0
	11–16	3RU1126-4AB0
	14–20	3RU1126-4BB0
	17–22	3RU1126-4CB0
	20–25	3RU1126-4DB0
3RU113-for direct mounting to 3RT103 contactors		
3RT1033	5.5–8	3RU1136-1HB0
3RT1034	7–10	3RU1136-1JB0
3RT1035	9–12.5	3RU1136-1KB0
3RT1036	11–16	3RU1136-4AB0
	14–20	3RU1136-4BB0
	18–25	3RU1136-4DB0
	22–32	3RU1136-4EB0
	28–40	3RU1136-4FB0
	36–45	3RU1136-4GB0
	40–50	3RU1136-4HB0
3RU114-for direct mounting to 3RT104 contactors		
3RT1044	18–25	3RU1146-4DB0
3RT1045	22–32	3RU1146-4EB0
3RT1046	28–40	3RU1146-4FB0
	36–50	3RU1146-4HB0
	35–63	3RU1146-4JB0
	57–75	3RU1146-4KB0
	70–90	3RU1146-4LB0
	80–100	3RU1146-4MB0

Solid-State Overload Relays

SIRIUS 3RB10 Solid State Overload Relays

For Contactor Type	Setting Range Amps	Manual / Automatic Reset		Manual Reset Only	
		Class 10 Catalogue No.	Class 20 Catalogue No.	Class 10 Catalogue No.	Class 20 Catalogue No.
3RB101-for direct mounting to 3RT101 contactors					
3RT1015	0.1–0.4	3RB1016-1RBO	3RB1016-2RBO	3RB1015-1RBO	3RB1015-2RBO
3RT1016	0.4–1.6	3RB1016-1NBO	3RB1016-2NBO	3RB1015-1NBO	3RB1015-2NBO
3RT1017	1.3–6	3RB1016-1PBO	3RB1016-2PBO	3RB1015-1PBO	3RB1015-2PBO
	3–12	3RB1016-1SBO	3RB1016-2SBO	3RB1015-1SBO	3RB1015-2SBO
3RB102-for direct mounting to 3RT102 contactors					
3RT1023	0.1–0.4	3RB1026-1RBO	3RB1026-2RBO	3RB1025-1RBO	3RB1025-2RBO
3RT1024	0.4–1.6	3RB1026-1NBO	3RB1026-2NBO	3RB1025-1NBO	3RB1025-2NBO
3RT1025	1.5–6	3RB1026-1PBO	3RB1026-2PBO	3RB1025-1PBO	2RB1025-2PBO
3RT1026	3–12	3RB1026-1SBO	3RB1026-2SBO	3RB1025-1SBO	3RB1025-2SBO
	6–25	3RB1026-1QBO	3RB1026-2QBO	3RB1025-1QBO	3RB1025-2QBO
3RB103-for direct mounting to 3RT103 contactors					
3RT1033	6–25	3RB1036-1QBO	3RB1036-2QBO	3RB1035-1QBO	3RB1035-2QBO
3RT1034	13–50	3RB1036-1UBO	3RB1036-2UBO	3RB1035-1UBO	3RB1035-2UBO
3RT1035					
3RT1037					
3RB104 -for direct mounting 3RT104 contactors					
3RT1044	13–50	3RB1046-1UBO	3RB1046-2UBO	3RB1045-1UBO	3RB1045-2UBO
3RT1045	25–100	3RB1046-1EBO	3RB1046-2EBO	3RB1045-1EBO	3RB1045-2EBO
3RT1046					
3RB105-for direct mounting to 3RT105 contactors					
3RT1054	50–200 ¹	3RB1056-1FWO ¹	3RB1056-2FWO ¹	3RB1055-1FWO ¹	3RB1055-2FWO ¹
3RT1055	50–200 ²	3RB1056-1FGO ²	3RB1056-2FGO ²	3RB1055-1FGO ²	3RB1055-2FGO ²
3RT1056					
3RB106-for direct mounting to 3RT106 and 3RT107 contactors²					
3RB106	55–250	3RB1066-1GG0	3RB1066-2GG0	3RB1065-1GG0	3RB1065-2GG0
3RB107	200–540	3RB1066-1KG0	3RB1066-2KG0	3RB1065-1KG0	3RB1065-2KG0
	300–630	3RB1066-1LG0	3RB1066-2LG0	3RB1065-1LG0	3RB1065-2LG0

¹ Overload contains pass-through windows.

² Overload has busbar connections.

6.5 Contactor Maintenance for SIRIUS Contactors 3RT1036 and larger

1. Maintenance

Inspect all connections periodically and tighten if necessary. To inspect main contacts of the contactor, remove arc-chute by turning arc-chute to expose contacts. Discolouration and slight pitting indicate normal operation. Do not file contacts. Replacement is necessary only when contact material has worn thin. Always install arc-chute before re-energizing equipment. Overload relays are factory-sealed units and do not require any servicing.

2. Coil Change

1. Loosen the two captive coil-cover-fastening screws on opposite sides of the contactor.
2. Remove the upper part of the contactor body. It may be necessary to remove connections from the contactor in order to complete this procedure.
3. Remove the coil from the magnet.
4. Replace the coil following the foregoing steps in reverse. Note that the upper and lower part of contactor housing are keyed.

3. Replacing the Main Contacts

Fixed Contacts: Undo the fixing bolt. Remove the contact complete with its bolt and firmly tighten the replacement contact.

Moving Contacts: Take hold of the contact, press it gently against the spring, turn it through 90° and pull it out. Insert the replacement contact in the reverse order, lifting the spring disc slightly.

Contactors

SIRIUS 3RT 10-Pole with AC Coil, 3RT101 to 3RT104

Coil Voltage Codes**		
ACV 60Hz	ACV 50Hz	Code
24	24	C2 ¹
120	110	K6
208	208	M2
240	220	P6
277	–	U6
480	–	V6
600	–	T6

Replace the ** in the contactor catalogue number with a coil from the table above.

¹ For 3RT101 use B0.

Enclosed Amp Ratings		Single-Phase HP-Rating		Three-Phase HP Ratings				Auxiliary Contacts		Screw Terminals	Cage Clamp Terminals
AC-3	AC-1	115V	230V	200V	230V	460V	575V	NO	NC	Catalogue No.	Catalogue No.
3RT101											
7	18	–	–	1½	2	3	5	1	–	3RT1015-1A**1	3RT1015-2A**1
								–	1	3RT1015-1A**2	3RT1015-2A**2
9	22	⅓	1	2	3	5	7½	1	–	3RT1016-1A**1	3RT1016-2A**1
								–	1	3RT1016-1A**2	3RT1016-2A**2
12	22	–	2	3	3	7½	10	1	–	3RT1017-1A**1	3RT1017-2A**1
								–	1	3RT1017-1A**2	3RT1017-2A**2
3RT102											
9	40	⅓	1	2	3	5	7½	–	–	3RT1023-1A**0	3RT1023-3A**0
12	40	–	2	3	3	7½	10	–	–	3RT1024-1A**0	3RT1024-3A**0
17	40	1	3	5	5	10	15	–	–	3RT1025-1A**0	3RT1025-3A**0
25	40	2	3	7½	7½	15	20	–	–	3RT1026-1A**0	3RT1026-3A**0
3RT103											
28	50	2	5	7½	10	20	25	–	–	3RT1033-1A**0	3RT1033-3A**0
32	50	2	5	10	10	25	30	–	–	3RT1034-1A**0	3RT1034-3A**0
40	50	3	7½	10	15	30	40	–	–	3RT1035-1A**0	3RT1035-3A**0
50	55	3	10	15	15	40	50	–	–	3RT1036-1A**0	3RT1036-3A**0
3RT104											
65	100	5	15	20	25	50	60	–	–	3RT1044-1A**0	3RT1044-3A**0
80	120	7½	15	25	30	60	75	–	–	3RT1045-1A**0	3RT1045-3A**0
95	120	10	–	30	30	75	100	–	–	3RT1046-1A**0	3RT1046-3A**0

SIRIUS 3RT10 3-Pole with AC/DC Coil, 3RT105 to 3RT12

Coil Voltage Codes AC/DC**	
AC (40Hz to 60 Hz) and DC	Code
23 to 26 ¹	B3
42 to 48	D3
110 to 127 ¹	F3
200 to 220	M3
220 to 240 ¹	P3
240 to 277	U3
380 to 420	V3
440 to 480 ¹	R3
500 to 550	S3
575 to 600	T3

Replace the "" in the contactor catalogue. Number with a coil code from the table above.

Enclosed Amp Ratings		200V	Three-Phase HP Ratings			Auxiliary Contacts		Catalogue Number AC Coil
AC-3	AC-1		230V	460V	575V	NO	NC	
Contactors are supplied without lugs								
115	160	40	50	100	125	2	2	3RT1054-6A**6
150	185	50	60	125	150	2	2	2RT1055-6A**6
185	215	60	75	150	200	2	2	3RT1056-6A**6
225	275	75	75	150	200	2	2	3RT1064-6A**6
265	330	75	100	200	250	2	2	3RT1065-6A**6
300	330	100	125	250	300	2	2	3RT1066-6A**6
400	430	125	150	300	400	2	2	3RT1075-6A**6
500	610	150	200	400	500	2	2	3RT1076-6A**6
Vacuum contactors								
225	330	75	75	150	200	2	2	3RT1264-6A**6
265	330	75	100	200	250	2	2	3RT1265-6A**6
300	330	100	125	250	300	2	2	3RT1266-6A**6
400	610	125	150	300	400	2	2	3RT1275-6A**6
500	610	150	200	400	500	2	2	3RT1276-6A**6

3RT1 Terminal Blocks

Description	Contactor	Wire Size	Catalogue No
1 Kit = Terminal block. 1 kit necessary for each line and load.	3RT1.54	6 AWG to 2/0, max. two 1/0	3RT1955-4G
	3RT1.5	6 AWG to 3/0, max. one 3/0 & (1) 4 AWG	3RT1956-4G
	3RT1.6/3RT1.7	2/0 to 600 kcmil, max. one 500kcmil and one 600kcmil	3RT1966-4G ²

¹ Standard coil voltage range

² Control power take-off included.

7.0 Troubleshooting

The following table lists troubles encountered with motor control centers, their causes and solutions. This table is of a general nature and covers only the main causes of trouble.

Misapplication of a device can be a cause of serious trouble. It should be noted here that misapplication is a major cause of motor control trouble and should always be considered when a device is not functioning properly.

Actual physical damage or broken parts can usually be found quickly and replaced. Damage due to water or flood conditions requires special treatment. Contact your local Siemens office.

Trouble	Cause	Solution
Contacts		
Contact Chatter (also see "Noisy Magnet")	<ol style="list-style-type: none"> Poor contact in control circuit. Low voltage. 	<ol style="list-style-type: none"> Replace the contact device or use holding circuit interlock (three-wire control). Check coil terminal voltage and voltage dips during starting.
Welding or Freezing	<ol style="list-style-type: none"> Abnormal inrush of current. Rapid jogging. Insufficient tip pressure. Low voltage preventing magnet from sealing. Foreign matter preventing contacts from closing. Short circuit or ground fault. 	<ol style="list-style-type: none"> Check for grounds, shorts or excessive motor load current, or use larger contactor. Install larger device rated for jogging service. Replace contacts and springs; check contact carrier for deformation or damage. Check coil terminal voltage and voltage dips during starting. Clean contacts with contact cleaner. Contacts, starters and control accessories used with very small current or low voltage should also be cleaned with the proper contact cleaner. Remove fault and check to be sure fuse or breaker size is correct.
Short Tip Life or Overheating of Tips	<ol style="list-style-type: none"> Filing or dressing. Interrupting excessively high currents. Excessive jogging. Weak tip pressure. Dirt or foreign matter on contact surface Short circuits or ground fault. Loose connection in power circuit. Sustained overload. 	<ol style="list-style-type: none"> Do not file silver tips. Rough spots or discoloration will not harm tips or impair their efficiency. Install larger device or check for grounds, shorts or excessive motor currents. Install larger device rated for jogging service. Replace contacts and springs; check contact carrier for deformation or damage. Clean contacts with contact cleaner. Take steps to reduce entry of foreign matter into enclosure. Remove fault and check to be sure fuse or breaker size is correct. Clear and tighten. Check for excessive motor load current or install larger device.
Coils		
Open Circuit	<ol style="list-style-type: none"> Mechanical damage. 	<ol style="list-style-type: none"> Handle and store coils carefully.

Trouble	Cause	Solution
Overheated Coil	<ol style="list-style-type: none"> 1. Over-voltage or high ambient temperature. 2. Incorrect coil. 3. Shorted turns caused by mechanical damage or corrosion. 4. Under-voltage; failure of magnet to seal in. 5. Dirt or rust on pole faces. 6. Mechanical obstruction. 	<ol style="list-style-type: none"> 1. Check coil terminal voltage, which should not exceed 110% of coil rating. 2. Install correct coil. 3. Replace coil. 4. Check coil terminal voltage, which should be at least 80% of coil rating. 5. Clean pole faces. 6. WITH POWER OFF, check for free movement of contact and armature assembly.
Overload Relays		
Tripping	<ol style="list-style-type: none"> 1. Sustained overload. 2. Loose or corroded connection 3. Excessive coil voltage. 	<ol style="list-style-type: none"> 1. Check for excessive motor currents or current unbalance, and correct cause. 2. a) Clean and tighten. b) Replace all insulators showing deterioration or deposit. 3. Voltage should not exceed 110% of coil rating.
Failure to Trip	<ol style="list-style-type: none"> 1. Mechanical binding, dirt, corrosion, etc. 2. Relay previously damaged by short circuit. 3. Relay contact welded or not in series with contactor coil. 	<ol style="list-style-type: none"> 1. Replace relay and thermal units. 2. Replace relay and thermal units. 3. Check circuit for a fault and correct condition. Replace contact or entire relay as necessary.
Magnetic and Mechanical Parts		
Noisy Magnet	<ol style="list-style-type: none"> 1. Broken shading coil. 2. Dirt or rust on magnet faces. 3. Low voltage. 	<ol style="list-style-type: none"> 1. Replace magnet and armature. 2. Clean. 3. Check coil terminal voltage and voltage dips during starting.
Failure to Pick up and Seal	<ol style="list-style-type: none"> 1. No control voltage. 2. Low voltage. 3. Mechanical obstruction. 4. Coil open or overheated. 5. Wrong coil. 	<ol style="list-style-type: none"> 1. Check and control circuit for loose connection or poor continuity of contacts. 2. Check coil terminal voltage and voltage dips during starting. 3. WITH POWER OFF, check for free movement of contact and armature assembly. 4. Replace. 5. Replace.
Failure to Drop Out	<ol style="list-style-type: none"> 1. Gummy substance on pole faces. 2. Voltage not removed. 3. Worn or corroded parts causing binding. 4. Residual magnetism due to lack of air gap in magnet path. 5. Contacts welded. 	<ol style="list-style-type: none"> 1. Clean pole faces. 2. Check coil terminal voltage and control circuit. 3. Replace parts. 4. Replace magnet and armature. 5. Replace contactor.
Limit Switches		
Broken Parts	<ol style="list-style-type: none"> 1. Over-travel of actuator. 	<ol style="list-style-type: none"> 1. Use resilient actuator or operate within tolerance of the device.
Manual Starters		
Failure to Reset	<ol style="list-style-type: none"> 1. Latching mechanism worn or broken. 	<ol style="list-style-type: none"> 1. Replace starter.

8.0 MCC Optional Equipment

Also available with Siemens Motor Control Center:

Samm's Unit

Soft Start

Variable Frequency Drive

Programmable Logical Center

Electronic Metering

For more information, contact your local Siemens office.